

## Interchangeable Lens Digital Camera

# α7R<sup>III</sup>

E-mount

Operating Instructions



### **“Help Guide” (Web manual)**

Refer to “Help Guide” for in-depth instructions on the many functions of the camera.

[https://rd1.sony.net/help/ilc/2050/h\\_zz/](https://rd1.sony.net/help/ilc/2050/h_zz/)

# Check out the Help Guide!



The “Help Guide” is an on-line manual that you can read on your computer or smartphone. Refer to it for details on menu items, advanced usage, and the latest information on the camera.



Scan here

[https://rd1.sony.net/help/ilc/2050/h\\_zz/](https://rd1.sony.net/help/ilc/2050/h_zz/)

ILCE-7RM3A Help Guide



## Operating Instructions (this book)



This manual introduces some basic functions.

For the quick start guide, see “Startup guide” (page 24). The “Startup guide” introduces the initial procedures from when you open the package until you release the shutter for the first shot.

## In-Camera Guide



The [In-Camera Guide] shows explanations of the menu items on the monitor of the camera.

You can quickly pull up information during shooting.

To use the [In-Camera Guide] function, some settings must be made beforehand. For details, search “In-Camera Guide” in the Help Guide.



# Table of contents

Check out the Help Guide!.....	2
Notes on using your camera.....	6



## Preparations for shooting

Checking the camera and the supplied items .....	10
Identifying parts.....	11
Front side .....	11
Rear side .....	12
Top side/Side view .....	14
Bottom .....	18
Basic operations.....	19
Using the control wheel .....	19
Using the multi-selector.....	20
Using the Fn (Function) button .....	20
How to use the Quick Navi screen .....	21
Startup guide .....	24
Step 1: Charging the battery pack.....	24
Step 2: Inserting the battery pack into the camera.....	25
Step 3: Inserting a memory card.....	26
Step 4: Attaching a lens .....	28
Step 5: Setting the language and the clock.....	31
Step 6: Shooting images in auto mode .....	32

## Shooting

Focusing .....	34
Focus Mode .....	34
Auto focus .....	36
Focus Area .....	36
Manual Focus .....	39
Direct manual focus (DMF) .....	40
Continuous shooting .....	41
Using touch function .....	43
Touch Operation .....	43
Touch Panel/Pad .....	43
Touch Focus .....	44
Selecting a still image size/image quality .....	46
 JPEG Image Size .....	46
 JPEG Quality .....	47
 File Format .....	47

## Shooting movies

Changing settings for movie recording .....	48
 File Format .....	48
 Record Setting .....	49





## Using network functions

Using the Wi-Fi/One-touch (NFC)/Bluetooth functions .....	52
Installing Imaging Edge Mobile .....	52
Recording location information to captured images .....	53
Transferring images to the FTP server .....	53
Connecting the camera to a wireless access point .....	54

## Using a computer

Connecting the camera to a computer .....	55
Connecting to a computer .....	55
Disconnecting the camera from the computer .....	56
Introduction to computer software .....	57
Imaging Edge Desktop .....	57
PlayMemories Home .....	57

## MENU items/List of icons

Using MENU items .....	58
List of MENU items .....	59
 1 (Camera Settings 1) .....	59
 2 (Camera Settings 2) .....	65
 (Network) .....	69
 (Playback) .....	70
 (Setup) .....	71
★ (My Menu) .....	74
List of icons on the monitor .....	75
Icons on the shooting screen .....	75
Icons on the playback screen .....	80

## About this product

Specifications .....	82
Memory cards that can be used .....	82
Specifications .....	84

<b>Index .....</b>	<b>88</b>
--------------------	-----------

For details on the Wi-Fi functions and NFC One-touch functions, refer to the "Help Guide" (page 2).

# Notes on using your camera

**Along with this section, also see “Precautions” in the Help Guide.**

## Notes on handling the product

- This camera is designed to be dust- and moisture-resistant, but is not waterproof or dust-proof.
- Do not leave the lens or the viewfinder exposed to a strong light source such as sunlight. Because of the lens’s condensing function, doing so may cause smoke, fire, or a malfunction inside the camera body or the lens. If you have to leave the camera exposed to a light source such as sunlight, attach the lens cap to the lens.
- If sunlight or a strong light source enters the camera through the lens, it may focus inside the camera and cause smoke or fire. Attach the lens cap to the lens when storing the camera. When you shoot with backlighting, keep the sun sufficiently far away from the angle of view. Note that smoke or fire may occur even if the light source is slightly away from the angle of view.
- Do not directly expose the lens to beams such as laser beams. That may damage the image sensor and cause the camera to malfunction.
- Do not look at sunlight or a strong light source through the lens when it is detached. This may result in unrecoverable damage to the eyes.

- This camera (including accessories) has magnet(s) which may interfere with pacemakers, programmable shunt valves for hydrocephalus treatment, or other medical devices. Do not place this camera close to persons who use such medical devices. Consult your doctor before using this camera if you use any such medical device.
- Do not leave the camera, the supplied accessories, or memory cards within the reach of infants. They may be accidentally swallowed. If this occurs, consult a doctor immediately.

## Notes on the monitor and electronic viewfinder

- The monitor and electronic viewfinder are manufactured using extremely high-precision technology, and over 99.99% of the pixels are operational for effective use. However, there may be some small black dots and/or bright dots (white, red, blue or green in color) that constantly appear on the monitor and electronic viewfinder. These are imperfections due to the manufacturing process and do not affect the recorded images in any way.

- When shooting with the viewfinder, you may experience symptoms such as eyestrain, fatigue, travel sickness, or nausea. We recommend that you take a break at regular intervals when you are shooting with the viewfinder.
- If the monitor or electronic viewfinder is damaged, stop using the camera immediately. The damaged parts may harm your hands, face, etc.
- If the same part of your skin touches the camera for a long period of time while using the camera, even if the camera does not feel hot to you, it may cause symptoms of a low-temperature burn such as redness or blistering. Pay special attention in the following situations and use a tripod, etc.
  - When using the camera in a high-temperature environment
  - When someone with poor circulation or impaired skin sensation uses the camera
  - When using the camera with the [Auto Pwr OFF Temp.] set to [High].

### Notes on continuous shooting

During continuous shooting, the monitor or viewfinder may flash between the shooting screen and a black screen. If you keep watching the screen in this situation, you may experience uncomfortable symptoms such as feeling of unwellness. If you experience uncomfortable symptoms, stop using the camera, and consult your doctor as necessary.

### Notes on recording for long periods of time or recording 4K movies

- Camera body and battery may get warm with use – this is normal.

### Sony lenses/accessories

Using this unit with products from other manufacturers may affect its performance, leading to accidents or malfunction.

### On the data specifications described in this manual

The data on performance and specifications are defined under the following conditions, except as described in this manual: at an ordinary ambient temperature of 25°C (77°F), and using a battery pack that has been fully charged until the charge lamp has turned off.

## Warning on copyright

Television programs, films, videotapes, and other materials may be copyrighted. Unauthorized recording of such materials may be contrary to the provisions of the copyright laws.

## Notes on location information

If you upload and share an image tagged with a location, you may accidentally reveal the information to a third party. To prevent third parties from obtaining your location information, set [□] Loc. Info. Link Set.] to [Off] before shooting images.

## Notes on discarding or transferring this product to others

When discarding or transferring this product to others, make sure to perform the following operation to protect private information.

- [Setting Reset] → [Initialize].

## Notes on discarding or transferring a memory card to others

Executing [Format] or [Delete] on the camera or a computer may not completely delete the data on the memory card. When transferring a memory card to others, we recommend that you delete the data completely using data deletion software. When discarding a memory card, we recommend that you physically destroy it.

## Note on network functions

When you use network functions, unintended third parties on the network may access the camera, depending on the usage environment.

For example, unauthorized access to the camera may occur in network environments to which another network device is connected or can connect without permission. Sony bears no responsibility for any loss or damage caused by connecting to such network environments.

## How to turn off wireless network functions (Wi-Fi, etc.) temporarily

When you board an airplane, etc., you can turn off all wireless network functions temporarily using [Airplane Mode].

## Power Cord

For the customers in the UK, Ireland, Malta, Cyprus and Saudi Arabia Use the power cord (A). For safety reasons, the power cord (B) is not intended for above countries/regions and shall therefore not be used there. For the customers in other EU countries/regions Use the power cord (B).

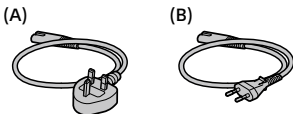



## **For Customers in the U.S.A.**

For question regarding your product or for the Sony Service Center nearest you, call 1-800-222-SONY (7669).

### **Supplier's Declaration of Conformity**

Trade Name: SONY

Model: WW186333

Responsible Party: Sony Electronics  
Inc.

Address: 16535 Via Esprillo, San  
Diego, CA 92127 U.S.A.

Telephone Number: 858-942-2230

This device complies with part 15 of the FCC rules. Operation is subject to the following two conditions:

(1) This device may not cause harmful interference, and (2) this device must accept any interference received, including interference that may cause undesired operation.

## Checking the camera and the supplied items

The number in parentheses indicates the number of pieces.

- Camera (1)
- Battery charger (1)



- Power cord (mains lead) (1)\*



\* Multiple power cords may be supplied with this equipment. Use the appropriate one that matches your country/region. See page 8.

- Rechargeable battery pack NP-FZ100 (1)



- USB Type-C® cable (1)

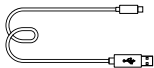

- Shoulder strap (1)

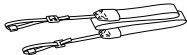

- Body cap (1) (Attached to the camera)



- Cable protector (1)



- Shoe cap (1) (Attached to the camera)



- Eyepiece cup (1) (Attached to the camera)



- Operating Instructions (1) (this manual)

- Reference Guide (1)

# Identifying parts

See the pages in parentheses for details.

## Front side

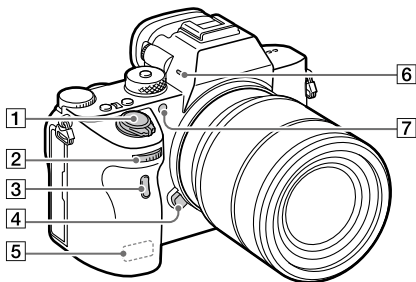

- 1 ON/OFF (Power) switch (31)/Shutter button (32)
- 2 Front dial  
You can quickly adjust the settings for each shooting mode.
- 3 Remote sensor
- 4 Lens release button (30)
- 5 Wi-Fi/Bluetooth antenna (built-in) (52)
- 6 Microphone  
Do not cover this part during movie recording. Doing so may cause noise or lower the volume.
- 7 AF illuminator (61)/Self-timer lamp

## When the lens is removed

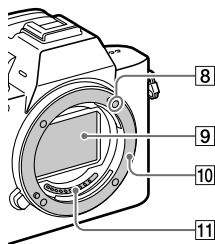

- 8 Mounting index (29)
- 9 Image sensor\*
- 10 Mount
- 11 Lens contacts\*

\* Do not directly touch these parts.

## Rear side

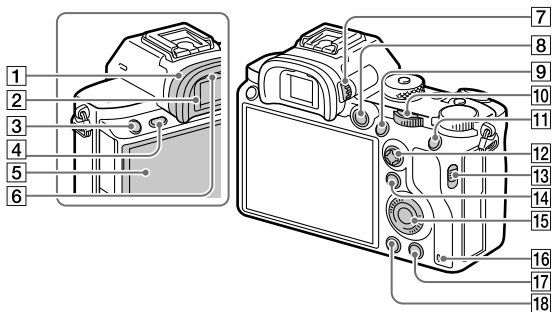

### 1 Eyepiece cup

#### To remove the eyepiece cup

Push the grips at the bottom of the eyepiece cup to the left and right and lift up the cup.

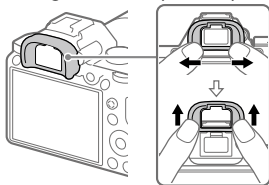

Remove the eyepiece cup when attaching an angle finder (sold separately). Also, select MENU → 2 (Camera Settings 2) → [FINDER/MONITOR], and then switch to [Viewfinder (Manual)] or [Monitor (Manual)].

### 2 Viewfinder

### 3 C3 button (Custom button 3) (68)/ (Protect) button

### 4 MENU button (58)

### 5 Monitor (For touch operation: Touch panel/Touch pad) (43) You can adjust the monitor to an easily viewable angle and shoot from any position.



### 6 Eye sensor

**7 Diopter-adjustment dial**

Adjust the diopter-adjustment dial according to your eyesight until the display appears clearly in the viewfinder. If it is hard to operate the diopter-adjustment dial, remove the eyepiece cup before operating the dial.

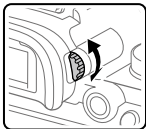
**8 MOVIE (Movie) button (33)****9 For shooting: AF-ON (AF On) button**

For viewing:  (Enlarge Image) button

**10 Rear dial**

You can quickly adjust the settings for each shooting mode.

**11 For shooting: AEL button**

For viewing:  (Image Index) button

**12 Multi-selector (20)****13 Media slot cover switch****14 For shooting: Fn (Function) button (20, 68)**

For viewing:  (Send to Smartphone) button

You can display the screen for [Send to Smartphone] by pressing this button.



**15 Control wheel (19)****16 Access lamp****17 For shooting: C4 button (Custom button 4) (68)**

For viewing:  (Delete) button (33)

**18  (Playback) button (33)**

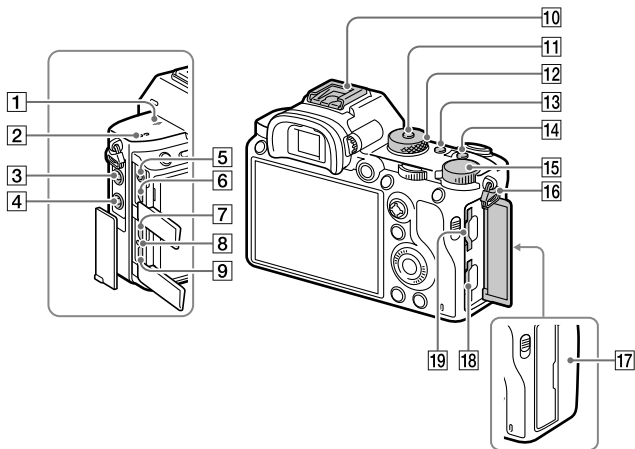
## Top side/Side view



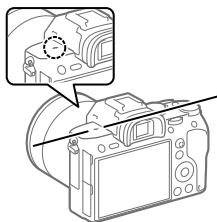

- 1  Image sensor position mark
- The image sensor is the sensor that converts light into an electric signal. The  mark shows the location of the image sensor. When you measure the exact distance between the camera and the subject, refer to the position of the horizontal line.





- If the subject is closer than the minimum shooting distance of the lens, the focus cannot be confirmed. Make sure you put enough distance between the subject and the camera.

## 2 Speaker

- 3**  **(Microphone) jack**  
When an external microphone is connected, the built-in microphone turns off automatically. When the external microphone is a plugin-power type, the power of the microphone is supplied by the camera.
- 4**  **(Flash sync) terminal**
- 5**  **(Headphones) jack**
- 6** **HDMI micro jack**
- 7** **USB Type-C terminal (16, 55)**
- 8** **Charge lamp**
- 9** **Multi/Micro USB Terminal\* (16, 55)**  
This terminal supports Micro USB-compatible devices.
- 10** **Multi Interface Shoe\***  
Some accessories may not go in all the way and protrude backward from the Multi interface shoe. However, when the accessory reaches the front end of the shoe, the connection is completed.
- 11** **Mode dial lock release button**
- 12** **Mode dial (33)**
- 13** **C2 button (Custom button 2) (68)**
- 14** **C1 button (Custom button 1) (68)**
- 15** **Exposure compensation dial**

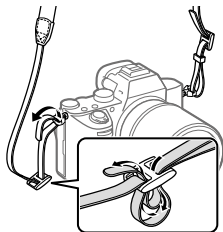
- 16** **Hooks for shoulder strap**  
Attach both ends of the strap onto the camera.



- 17**  **(N mark) (52)**
- This mark indicates the touch point for connecting the camera and an NFC-enabled Smartphone.

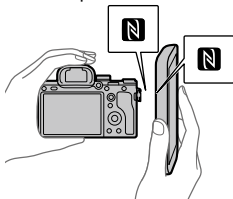

- NFC (Near Field Communication) is an international standard of short-range wireless communication technology.
- 18** **SLOT 1 (Memory card slot 1) (26)**  
Supports SD cards only (compatible with UHS-I and UHS-II)

## 19 SLOT 2 (Memory card slot 2) (28)

Supports SD cards  
(compatible with UHS-I) and  
Memory Stick PRO Duo media

- \* For details on compatible accessories for the multi interface shoe and the Multi/Micro USB Terminal, visit the Sony website, or consult your Sony dealer or local authorized Sony service facility. Accessories for the Accessory Shoe can also be used. Operations with other manufactures' accessories are not guaranteed.

**mi** Multi  
Interface Shoe

Accessory Shoe

### Notes on USB terminals

You can use either the USB Type-C terminal or the Multi/Micro USB Terminal for supplying power, charging the battery, and USB communications. However, you cannot conduct these operations with both terminals simultaneously.

- The battery charging time does not change according to the terminal you use.
- You can use accessories for the Multi/Micro USB Terminal, such as a remote commander (sold separately), while supplying power or performing PC Remote shooting using the USB Type-C terminal.



## Notes on the cable protector

Use the cable protector to prevent a cable from being disconnected when shooting images with the cable connected.

### To attach the cable protector

- ① Thread the cable through the cable protector.
- ② Open both of the jack covers on the monitor side and insert the cable into one of the jacks.
- ③ Fit the hook of the cable protector into the slit under the Multi/Micro USB Terminal.
  - Attach the cable protector as illustrated so that the upper jack cover fits into the notch in the cable protector, and then insert the claw of the cable protector into the slit next to the HDMI micro jack.
- ④ Push the attachment screw in and turn it to secure the cable protector.
- ⑤ Insert the cable into the holding part and then secure the cable with the fixing dial.

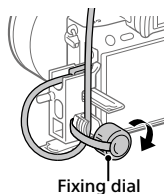
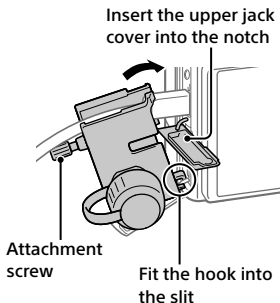

### To remove the cable protector

Loosen the attachment screw. Push down the upper part of the cable protector and pull it out as illustrated.

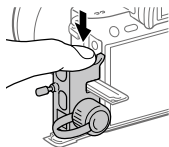

## Bottom

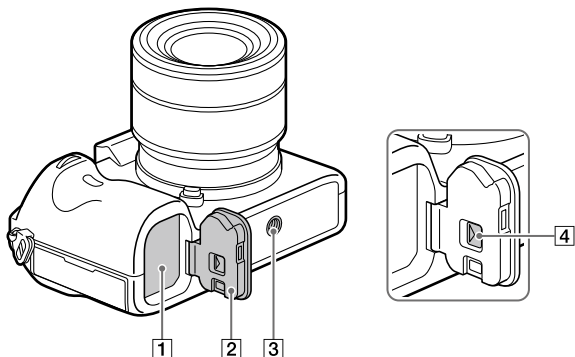

**1** Battery insertion slot (25)

**2** Battery cover (25)

**3** Tripod socket hole  
Supports 1/4-20 UNC screws

Use a tripod with a screw less than 5.5 mm (7/32 inches) long. Otherwise, you cannot firmly secure the camera, and damage to the camera may occur.

**4** Battery cover release lever

# Basic operations

## Using the control wheel

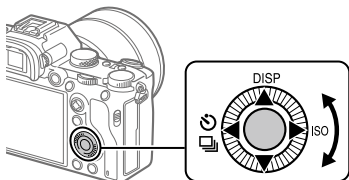

- You can select setting items by turning or pressing the top/bottom/left/right side of the control wheel. Your selection is determined when you press the center of the control wheel.
- The DISP (Display Setting),  (Drive Mode), and ISO (ISO) functions are assigned to the top/left/right side of the control wheel. In addition, you can assign selected functions to the left/right/bottom side and the center of the control wheel, and to the rotation of the control wheel.
- During playback, you can display the next/previous image by pressing the right/left side of the control wheel or by turning the control wheel.

## Using the multi-selector

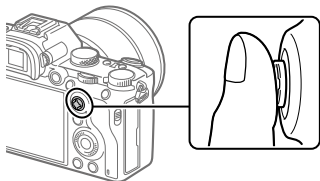

- Put your finger right on top of the multi-selector to manipulate it more precisely.
- When [Focus Area] is set to [Zone], [Flexible Spot], or [Expand Flexible Spot], you can move the focus area by pressing the multi-selector up/down/left/right.
- The [Focus Standard] function is assigned to the center of the multi-selector in the default settings.

## Using the Fn (Function) button

You can register frequently used functions to the Fn (function) button and recall them while shooting. Up to 12 frequently used functions can be registered to the Fn (Function) button.

- 1 Press the DISP on the control wheel repeatedly to display a screen mode other than [For viewfinder], and then press the Fn (Function) button.**

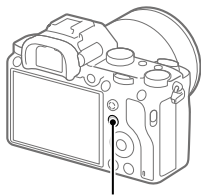

- 2 Select the desired function by pressing the top/bottom/left/right side of the control wheel.**

### 3 Select the desired setting by turning the front dial, and press the center of the control wheel.

- Some functions can be fine-tuned using the rear dial.

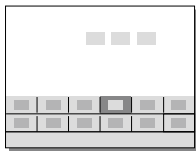

### To adjust settings from the dedicated setting screens

Select the desired function in step 2, then press the center of the control wheel. The dedicated setting screen for the function will appear. Follow the operating guide to adjust settings.



Operation guide

## How to use the Quick Navi screen

The Quick Navi screen is a function optimized for shooting with the viewfinder, that lets you control settings directly.

- 1 Select **MENU** → 2 (Camera Settings 2) → [DISP Button] → [Monitor].
- 2 Place a ✓ mark on [For viewfinder] and then select [Enter].
- 3 Press the **DISP** on the control wheel to set the screen mode to [For viewfinder].

---

## 4 Press the Fn button to switch to the Quick Navi screen.

- The displayed contents and their positions in the illustrations are just guidelines, and may differ from the actual displays.

### Auto mode



### P/A/S/M mode



---

## 5 Select a function to set by pressing the top/bottom/left/right side of the control wheel.

---

## 6 Select the desired setting by turning the front dial.

- Some functions can be fine-tuned using the rear dial.
-

## ■ To adjust settings from the dedicated setting screens

Select the desired function in step 5, then press the center of the control wheel. The dedicated setting screen for the function will appear. Follow the operating guide to adjust settings.



Operation guide

### Note

- Items that are gray on the Quick Navi screen are not adjustable.
- When using functions such as [Creative Style] or [Picture Profile], some settings can only be controlled from the dedicated screen.

# Startup guide

## Step 1: Charging the battery pack

### 1 Insert the battery pack into the battery charger.

- Place the battery pack on the battery charger in the direction of the ▲.
- Slide the battery pack in the direction of the arrow as far as it will go.

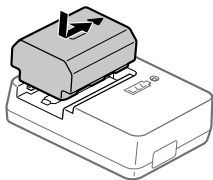

### 2 Connect the power cord (supplied) to the battery charger, and connect the battery charger to the wall outlet (wall socket).

The CHARGE lamp on the battery charger will light up in orange and charging will start.

#### CHARGE lamp (orange)

Lit: Charging

Flashing: Charging error or charging paused temporarily because the camera is not within the proper temperature range

- When charging is finished, the CHARGE lamp and all indicators turn off.
- Charging time (full charge): approximately 150 min. (when charging a fully depleted battery pack at a temperature of 25°C (77°F))
- When you use a completely new battery pack or a battery pack that has not been used for a long time, the CHARGE lamp may flash quickly when the battery is charged for the first time. If this happens, remove the battery pack and then re-insert it to recharge.
- Be sure to use only genuine Sony brand battery packs.

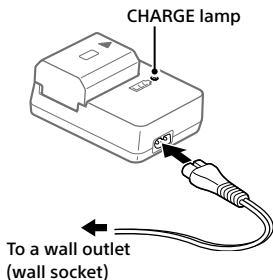



## Step 2: Inserting the battery pack into the camera

**1** Open the battery cover.

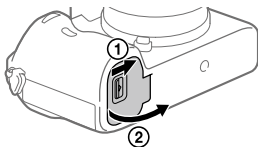

**2** Insert the battery pack while pressing the lock lever with the tip of the battery until the battery locks into place.

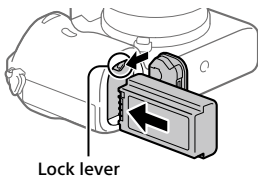

**3** Close the cover.

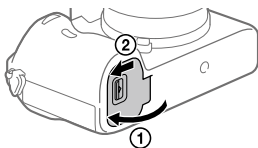

## ■ To charge the battery pack while it is inserted in the camera

Turn the camera off and connect it to a device such as a computer using the USB cable.

If you turn on the camera, power will be supplied from the computer or the device that you connected, and you will be able to operate the camera. However, the battery pack will not charge.

Use the USB Type-C cable (supplied) or a USB-standard cable.

## ■ To remove the battery pack

Make sure that the access lamp (page 13) is not lit, and turn off the camera. Then, slide the lock lever and remove the battery pack. Be careful not to drop the battery pack.

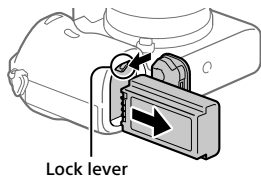

## Step 3: Inserting a memory card

For details on memory cards that can be used with this camera, refer to page 82.

### 1 Open the memory card cover.

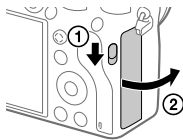

## 2 Insert the SD card into the slot 1.

Slot 1 (lower): Supports SD cards (compatible with UHS-I and UHS-II)

Slot 2 (upper): Supports SD cards (compatible with UHS-I) and Memory Stick PRO Duo media

- With the notched corner facing in the direction illustrated, insert the memory card until it clicks into place.
- You can change which memory card slot to use by selecting MENU →  (Setup) → [Rec. Media Settings] → [Prioritize Rec. Media]. The slot 1 is used in the default settings.
- Use the slot 1 when you are only using one SD card.
- Use the slot 2 when you are using Memory Stick media. In this case, set [Prioritize Rec. Media] to [Slot 2].

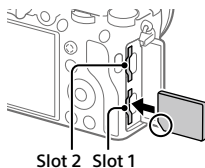

## 3 Close the cover.

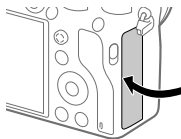

### Hint

- When you use a memory card with the camera for the first time, it is recommended that you format the card on the camera for more stable performance of the memory card (page 73).

### Note

- Do not insert a Memory Stick media into the slot 1. It may cause a malfunction.

## To remove the memory card

Open the memory card cover.

Make sure that the access lamp (page 13) is not lit, and then push in the memory card once to remove it.

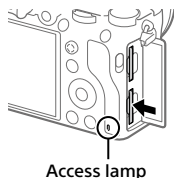

## To record to memory cards in two slots

The slot 1 is used in the default settings. If you do not intend to change the settings and will only use one memory card, use the slot 1.

By inserting another memory card into the slot 2, you can record the same images to two memory cards simultaneously or record a different type of image (still images/movies) to each memory card ([Recording Mode] under [Rec. Media Settings]) (page 73).

## Step 4: Attaching a lens

### 1 Remove the body cap from the camera and the rear lens cap from the rear of the lens.

- When changing the lens, work quickly in a dust-free environment to keep dust or debris from getting inside the camera.
- It is recommended that you attach the front lens cap when you have done shooting.

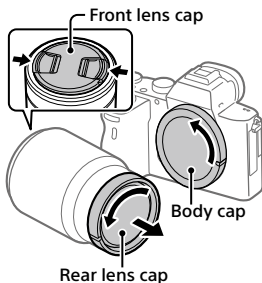

---

## 2 Mount the lens by aligning the two white index marks (mounting indexes) on the lens and camera.

- Hold the camera with the lens facing down to prevent dust or debris from entering the camera.

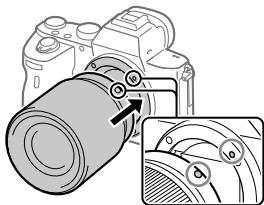

---

## 3 While pushing the lens lightly toward the camera, turn the lens slowly in the direction of the arrow until it clicks into the locked position.

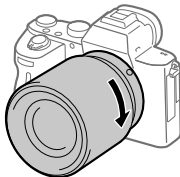

---

### Note

- Be sure to hold the lens straight and do not use force when attaching a lens.
- Do not press the lens release button when attaching a lens.
- The Mount Adaptor (sold separately) is required to use an A-mount lens (sold separately). For details, refer to the operating manual supplied with the Mount Adaptor.
- If you want to shoot full-frame images, use a full-frame size compatible lens.
- When carrying the camera with a lens attached, hold both the camera and the lens firmly.
- Do not hold the part of the lens that is extended for zoom or focus adjustment.

## To remove the lens

Keep pressing the lens release button and turn the lens in the direction of the arrow until it stops.

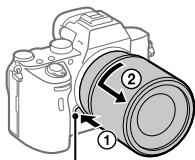

Lens release button

## Compatible lenses

Lenses compatible with this camera are as follows:

Lens		Compatibility with the camera
A-mount lens	Lens compatible with 35 mm full-frame format	✓ (An optional Mount Adaptor (sold separately) compatible with full-frame format is required)
	APS-C size dedicated lens	✓* (An optional Mount Adaptor (sold separately) is required)
E-mount lens	Lens compatible with 35 mm full-frame format	✓
	APS-C size dedicated lens	✓*

\* Images will be recorded in APS-C size. The angle of view will correspond to approximately 1.5 times the focal length indicated on the lens. (For example, the angle of view will correspond to 75 mm when a 50 mm-lens is attached.)

## Step 5: Setting the language and the clock

- 1 Set the ON/OFF (Power) switch to "ON" to turn on the camera.

ON/OFF (Power) switch

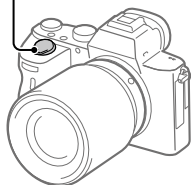

- 2 Select the desired language and then press the center of the control wheel.

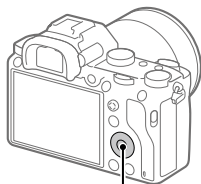

Control wheel

- 3 Make sure that [Enter] is selected on the screen and then press the center.
- 4 Select the desired geographic location and then press the center.
- 5 Select [Date/Time] using the top/bottom of the control wheel or by turning the control wheel, and then press the center.
- 6 Select the desired item by pressing the top/bottom/left/right side of the control wheel, and then press the center.

---

## 7 Repeat steps 5 and 6 to set other items, then select [Enter] and press the center.

---

### Hint

- To reset the date and time setting, use MENU (page 73).

### Note

- This camera does not have a function for inserting the date into images. You can insert the date into images and then save and print them using PlayMemories Home (for Windows only).

## Step 6: Shooting images in auto mode

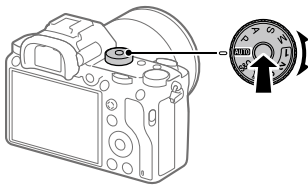

---

### 1 Press and hold the lock release button in the center of the mode dial, then turn the mode dial to set to **AUTO**.

The shooting mode will be set to  (Intelligent Auto).

---

### 2 Look into the viewfinder or the monitor and hold the camera.

---

### 3 Set the size of the subject by rotating the zoom ring of the lens when a zoom lens is attached.

---

### 4 Press the shutter button halfway down to focus.

- When the image is in focus, an indicator (such as ●) will light up.

---

### 5 Press the shutter button all the way down.

---



## ■ To shoot movies

Press the MOVIE button to start/stop recording.

## ■ To play back images

Press the  (Playback) button to play back images. You can select the desired image using the control wheel.

## ■ To delete displayed image

Press the  (Delete) button while an image is displayed to delete it. Select [Delete] using the control wheel on the confirmation screen, and then press the center of the control wheel to delete the image.

## ■ To shoot images in various shooting modes

Set the mode dial to the desired mode depending on the subject or the functions you want to use.

## Focusing

### Focus Mode

Selects the focus method to suit the movement of the subject.

---

**MENU** → 1 (Camera Settings 1) → **[Focus Mode]** → **desired setting.**

**AF-S (Single-shot AF):** The product locks the focus once focusing is complete. Use this when the subject is motionless.

**AF-A (Automatic AF):** [Single-shot AF] and [Continuous AF] are switched according to the movement of the subject. When the shutter button is pressed halfway down, the product locks the focus when it determines that the subject is motionless, or continues to focus when the subject is in motion. During continuous shooting, the product automatically shoots with Continuous AF from the second shot.

**AF-C (Continuous AF):** The product continues to focus while the shutter button is pressed and held halfway down. Use this when the subject is in motion. In [Continuous AF] mode, there is no beep when the camera focuses.

**DMF (DMF):** You can make fine adjustments manually after performing auto focusing, letting you focus on a subject more quickly than when using the manual focus from the beginning. This is convenient in situations such as macro shooting.

**MF (Manual Focus):** Adjusts the focus manually. If you cannot focus on the intended subject using auto focus, use manual focus.

---

## Focus indicator

- **(lit)**: The subject is in focus and the focus is locked.
- **(flashing)**: The subject is not in focus.
- **(lit)**: The subject is in focus. The focus will be adjusted continuously according to the movements of the subject.
- **(lit)**: Focusing is in progress.

## Subjects on which it is difficult to focus using auto focus

- Dark and distant subjects
- Subjects with poor contrast
- Subjects seen through glass
- Fast-moving subjects
- Reflective light or shiny surfaces
- Flashing light
- Back-lit subjects
- Continuously repetitive patterns, such as the facades of buildings
- Subjects in the focusing area with different focal distances

### Hint

- In [Continuous AF] mode, you can lock the focus by pressing and holding the button that has been assigned the [Focus Hold] function (page 68).
- When you set the focus to infinity in the manual focus mode or the direct manual focus mode, make sure that the focus is on a sufficiently distant subject by checking the monitor or the viewfinder.

### Note

- [Automatic AF] is available only when you are using a lens that supports phase detection AF.
- When [Continuous AF] or [Automatic AF] is set, the angle of view may change little by little while focusing. This does not affect the actual recorded images.
- Only [Continuous AF] and [Manual Focus] are available when shooting movies or when the mode dial is set to **S&Q**.

# Auto focus

## Focus Area

Selects the focusing area. Use this function when it is difficult to focus properly in the auto focus mode.

---

**MENU** →  **1 (Camera Settings 1)** → **[Focus Area]** → **desired setting.**





 **Wide:** Focuses on a subject covering the whole range of the screen automatically. When you press the shutter button halfway down in the still image shooting mode, a green frame is displayed around the area that is in focus.

 **Zone:** Select a zone on the monitor on which to focus, and the product will automatically select a focus area.

 **Center:** Focuses automatically on a subject in the center of the image. Use together with the focus-lock function to create the composition you want.

 **Flexible Spot:** Allows you to move the focusing frame to a desired point on the screen and focus on an extremely small subject in a narrow area.

 **Expand Flexible Spot:** If the product cannot focus on a single selected point, it uses focus points around the flexible spot as a secondary priority area for focusing.

     **Lock-on AF:** When the shutter button is pressed and held halfway down, the product tracks the subject within the selected autofocus area. This setting is available only when the [Focus Mode] is set to [Continuous AF]. Point the cursor at [Lock-on AF] on the [Focus Area] setting screen, and then adjust the desired area to start tracking using the left/right sides of the control wheel. You can also move the tracking start area to the desired point by designating the area as a zone, flexible spot or expand flexible spot.

---

## Examples of the focusing frame display

The focusing frame differs as follows.

### When focusing on a larger area

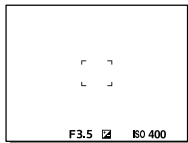

### When focusing on a smaller area

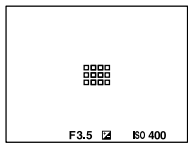

- When [Focus Area] is set to [Wide] or [Zone], the focusing frame may switch between “When focusing on a larger area” and “When focusing on a smaller area” depending on the subject or situation.
- When you attach an A-mount lens with a Mount Adaptor (LA-EA1 or LA-EA3) (sold separately) and [AF System] is set to [Phase Detection AF], the focusing frame for “When focusing on a smaller area” may be displayed.

### When focus is achieved automatically based on the whole range of the monitor

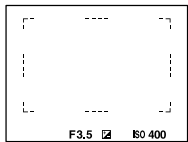

- When you use a zoom function other than the optical zoom, the [Focus Area] setting is disabled and the focusing frame is shown by the dotted line. The AF operates with priority on and around the center area.

## To move the focus area

- You can move the focus area in [Flexible Spot], [Expand Flexible Spot], or [Zone] by operating the multi-selector. If you assign [Focus Standard] to the center of the multi-selector beforehand, you can move the focusing frame back to the center of the monitor by pressing the center of the multi-selector.
- You can move the focusing frame quickly by touching and dragging it on the monitor. Set [Touch Operation] to [On] beforehand (page 43).

### Hint

- In the default settings, [Focus Area] is assigned to the C2 button.

### Note

- [Focus Area] is locked to [Wide] in the following situations:
  - [Intelligent Auto]
- The focus area may not light up during continuous shooting or when the shutter button is pressed all the way down at once.
- When the mode dial is set to  (Movie) or **S&Q**, or during movie shooting, [Lock-on AF] cannot be selected as the [Focus Area].

# Manual Focus

When it is difficult to focus properly in the autofocus mode, you can adjust the focus manually.

---

**1** MENU →  1 (Camera Settings 1) → [Focus Mode] → [Manual Focus].

---

**2** Rotate the focusing ring to achieve sharp focus.

- When you rotate the focusing ring, the focus distance is displayed on the screen. The focus distance is not displayed when the Mount Adaptor (sold separately) is attached.

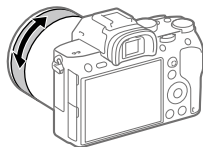

Shooting

---

**3** Press the shutter button fully down to shoot an image.

---

## Note

- When you use the viewfinder, adjust the diopter level to obtain the correct focus on the viewfinder (page 13).

## Direct manual focus (DMF)

You can make fine adjustments manually after performing auto focusing, letting you focus on a subject more quickly than when using the manual focus from the beginning. This is convenient in situations such as macro shooting.

---

**1** MENU →  1 (Camera Settings 1) → [Focus Mode] → [DMF].

---

**2** Press the shutter button halfway down to focus automatically.

---

**3** Keep the shutter button pressed halfway down, and then rotate the focusing ring to achieve a sharper focus.

- When you rotate the focusing ring, the focus distance is displayed on the screen. The focus distance is not displayed when the Mount Adaptor (sold separately) is attached.

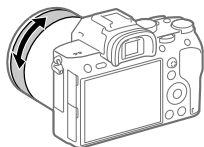

---

**4** Press the shutter button fully down to shoot an image.

---



# Continuous shooting



Shoots images continuously while you press and hold down the shutter button.

## 1 Select (Drive Mode) on the control wheel → [Cont. Shooting].

- You can also set the drive mode by selecting MENU →  1 (Camera Settings 1) → [Drive Mode].

## 2 Select the desired mode using the right/left side of the control wheel.

 **Hi+** **Continuous Shooting: Hi+**: Images are shot continuously at the maximum speed while you press and hold down the shutter button.

 **Hi** **Continuous Shooting: Hi** /  **MD** **Continuous Shooting: Mid** /  **Lo** **Continuous Shooting: Lo**: Subjects are easier to track because the subject is displayed in real-time on the monitor or viewfinder during shooting.

### Hint

- To continuously adjust the focus and exposure during continuous shooting, set as follows:
  - [Focus Mode]: [Continuous AF]
  - [ AEL w/ shutter]: [Off] or [Auto]

## Note

- The shooting speed during continuous shooting becomes slower when [RAW File Type] is set to [Uncompressed].
- The shooting speed during continuous shooting becomes slower when [e-Front Curtain Shut.] is set to [Off] in [Continuous Shooting: Hi], [Continuous Shooting: Mid] or [Continuous Shooting: Lo] mode.
- When the F-value is greater than F8 in [Continuous Shooting: Hi+], [Continuous Shooting: Hi] or [Continuous Shooting: Mid] mode, the focus is locked to the setting in the first shot.
- The subject is not displayed in real-time on the monitor or viewfinder when shooting in [Continuous Shooting: Hi+] mode.
- Continuous shooting is unavailable in the following situations:
  - [Picture Effect] is set to [Rich-tone Mono.].
  - [DRO/Auto HDR] is set to [Auto HDR].

## Displaying continuous shooting remaining time indicator (Cont. Shoot. Length)

Sets whether to display an indicator of the remaining time for which continuous shooting can be performed at the same shooting speed.

**MENU** →  **2 (Camera Settings 2)** → **[Cont. Shoot. Length]** → **desired setting.**

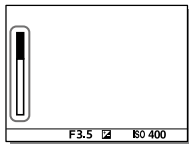

**Always Display:** Always displays the indicator when the drive mode is set to [Cont. Shooting].

**Shoot.-Only Display:** Displays the indicator only while continuous shooting is performed.

**Not Displayed:** Does not display the indicator.

## Hint

- When the internal camera memory for buffering is full, "SLOW" will be displayed and the continuous shooting speed will decrease.

# Using touch function

## Touch Operation

Sets whether to activate or not the touch operation of the monitor. Touch operations when shooting with the monitor are referred to as “touch panel operations,” and touch operations when shooting with the viewfinder are referred to as “touch pad operations.”

---

**MENU** →  (**Setup**) → [**Touch Operation**] → **desired setting**.

**On:** Activates the touch operation.

**Off:** Deactivates the touch operation.

---

## Touch Panel/Pad

Selects whether to activate touch panel operation when shooting with the monitor, or touch pad operation when shooting with the viewfinder.

---

**MENU** →  (**Setup**) → [**Touch Panel/Pad**] → **desired setting**.

**Touch Panel+Pad:** Activates both the touch panel operations when shooting with the monitor and touch pad operations when shooting with the viewfinder.

**Touch Panel Only:** Activates only the touch panel operations when shooting with the monitor.

**Touch Pad Only:** Activates only the touch pad operations when shooting with the viewfinder.

---

## Touch Focus

You can select a subject on which to focus using touch operations in the still image and movie recording modes.

**MENU** →  (Setup) → [Touch Operation] → [On].

### ■ Specifying the position where you want to focus in the still image mode

You can focus on the desired position by touching the monitor.

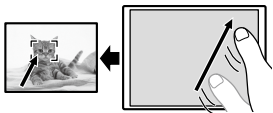

- ① Select a [Focus Area] other than [Flexible Spot] or [Expand Flexible Spot].
- ② **MENU** →  1 (Camera Settings 1) → [Center Lock-on AF] → [Off].
- ③ **Touch the monitor.**
  - When shooting with the monitor, touch the subject to focus.
  - When shooting with the viewfinder, you can move the position of the focus by touching and dragging on the monitor while looking through the viewfinder.



- When the shutter button is pressed halfway down, the camera focuses on the focusing frame. Press the shutter button all the way down to shoot images.
- To cancel focusing with touch operations, touch  or press the center of the control wheel if shooting with the monitor, and press the center of the control wheel if shooting with the viewfinder.

## ■ Specifying the position where you want to focus in the movie recording mode (spot focus)

The camera will focus on the touched subject. Spot focus is not available when shooting with the viewfinder.

- ① Select a [Focus Area] other than [Flexible Spot] or [Expand Flexible Spot].
- ② MENU →  1 (Camera Settings 1) → [Center Lock-on AF] → [Off].
- ③ Touch the subject on which you want to focus before or during recording.
  - When you touch the subject, the focus mode temporarily switches to manual focus and the focus can be adjusted using the focus ring.
  - To cancel spot focus, touch  or press the center of the control wheel.

### Hint

- In addition to the touch focus function, touch operations such as the following are also available.
  - When [Focus Area] is set to [Flexible Spot] or [Expand Flexible Spot], the focusing frame can be moved using touch operations.
  - When the [Focus Mode] is set to [Manual Focus], the focus magnifier can be used by double-tapping the monitor.



### Note

- The touch focus function is not available in the following situations:
  - When [Focus Mode] is set to [Manual Focus].
  - When using the digital zoom
  - When using the LA-EA2 or LA-EA4
  - When using the LA-EA1 or LA-EA3, and the shooting mode is set to [Movie]

# Selecting a still image size/image quality

## JPEG Image Size

The larger the image size, the more detail will be reproduced when the image is printed on large-format paper. The smaller the image size, the more images can be recorded.

**MENU** →  1 (Camera Settings 1) → [ JPEG Image Size] → desired setting.

When [  Aspect Ratio] is set to 3:2	
<b>L: 42M</b>	7952×5304 pixels
<b>M: 18M</b>	5168×3448 pixels
<b>S: 11M</b>	3984×2656 pixels

When [  Aspect Ratio] is set to 16:9	
<b>L: 36M</b>	7952×4472 pixels
<b>M: 15M</b>	5168×2912 pixels
<b>S: 8.9M</b>	3984×2240 pixels

### When recording in the APS-C-equivalent size

When [  Aspect Ratio] is set to 3:2	
<b>L: 18M</b>	5168×3448 pixels
<b>M: 11M</b>	3984×2656 pixels
<b>S: 4.5M</b>	2592×1728 pixels

When [  Aspect Ratio] is set to 16:9	
<b>L: 15M</b>	5168×2912 pixels
<b>M: 8.9M</b>	3984×2240 pixels
<b>S: 3.8M</b>	2592×1456 pixels



#### Note

- When [ File Format] is set to [RAW] or [RAW & JPEG], the image size for RAW images corresponds to "L."

## JPEG Quality

Selects the JPEG image quality when [ File Format] is set to [RAW & JPEG] or [JPEG].

---

**MENU** →  1 (Camera Settings 1) → [ JPEG Quality] → **desired setting.**



**Extra fine/Fine/Standard:** Since the compression rate increases from [Extra fine] to [Fine] to [Standard], the file size decreases in the same order. This allows more files to be recorded on one memory card, but the image quality is lower.

---

## File Format

Sets the file format for still images.

---

**MENU** →  1 (Camera Settings 1) → [ File Format] → **desired setting.**

**RAW:** Digital processing is not performed on this file format. Select this format to process images on a computer for professional purposes.

**RAW & JPEG:** A RAW image and a JPEG image are created at the same time. This is suitable when you need two image files, a JPEG for viewing, and a RAW for editing.



**JPEG:** The image is recorded in the JPEG format.

---

## Changing settings for movie recording

### File Format

Selects the movie file format.

**MENU** →  2 (Camera Settings 2) →  File Format → desired setting.

 File Format	Characteristics	
<b>XAVC S 4K</b>	Records movies in 4K resolution (3840×2160).	You can save movies on a computer using the PlayMemories Home software.
<b>XAVC S HD</b>	Records movies in crisper quality than AVCHD with larger amounts of data.	You can save movies on a computer using the PlayMemories Home software.
<b>AVCHD</b>	The AVCHD format has a high degree of compatibility with storage devices other than computers.	You can save movies on a computer or create a disc that supports this format using the PlayMemories Home software.

For details on memory cards that can be used for these formats, refer to page 82.



## Note

- When [File Format] is set to [AVCHD], the file size of movies is limited to approx. 2 GB. If the movie file size reaches approx. 2 GB during recording, a new movie file will be created automatically.
- Images will not appear on the monitor of the camera if you record movies while the camera is connected to an HDMI device with [File Format] set to [XAVC S 4K].
- When recording XAVC S 4K movies with [APS-C S35 Shooting] under [APS-C/Super 35mm] set to [Auto], the angle of view is equivalent to approx. 1.5 times the focal length indicated on the lens.

## Record Setting

Selects the frame rate and bit-rate for movie recording.

**MENU** →  **2 (Camera Settings 2)** → [Record Setting] → **desired setting.**

- The higher the bit-rate, the higher the image quality.

When [File Format] is set to [XAVC S 4K]

Record Setting	Bit-rate	Description
30p 100M/25p 100M	Approx. 100 Mbps	Records movies in 3840×2160 (30p/25p).
30p 60M/25p 60M	Approx. 60 Mbps	Records movies in 3840×2160 (30p/25p).
24p 100M*	Approx. 100 Mbps	Records movies in 3840×2160 (24p).
24p 60M*	Approx. 60 Mbps	Records movies in 3840×2160 (24p).

\* Only when [NTSC/PAL Selector] is set to NTSC

## When [File Format] is set to [XAVC S HD]

Record Setting	Bit-rate	Description
60p 50M/50p 50M	Approx. 50 Mbps	Records movies in 1920×1080 (60p/50p).
60p 25M/50p 25M	Approx. 25 Mbps	Records movies in 1920×1080 (60p/50p).
30p 50M/25p 50M	Approx. 50 Mbps	Records movies in 1920×1080 (30p/25p).
30p 16M/25p 16M	Approx. 16 Mbps	Records movies in 1920×1080 (30p/25p).
24p 50M*	Approx. 50 Mbps	Records movies in 1920×1080 (24p).
120p 100M/100p 100M	Approx. 100 Mbps	Records high-speed movies in 1920×1080 (120p/100p). You can record movies in 120 fps or 100 fps. <ul style="list-style-type: none"> <li>You can create smoother slow-motion movies by using compatible editing devices.</li> </ul>
120p 60M/100p 60M	Approx. 60 Mbps	Records high-speed movies in 1920×1080 (120p/100p). You can record movies in 120 fps or 100 fps. <ul style="list-style-type: none"> <li>You can create smoother slow-motion movies by using compatible editing devices.</li> </ul>

\* Only when [NTSC/PAL Selector] is set to NTSC

## When [File Format] is set to [AVCHD]

Record Setting	Bit-rate	Description
60i 24M (FX)/ 50i 24M (FX)	24 Mbps at maximum	Records movies in 1920×1080 (60i/50i).
60i 17M (FH)/ 50i 17M (FH)	Approx. 17 Mbps on average	Records movies in 1920×1080 (60i/50i).

## Note

- Creating an AVCHD recording disc from movies that were recorded with [60i 24M (FX)]/[50i 24M (FX)] as the [Record Setting] takes a long time because the image quality of movies is converted. If you want to store movies without converting them, use a Blu-ray Disc.
- [120p]/[100p] cannot be selected for the following settings.
  - [Intelligent Auto]

## Using the Wi-Fi/One-touch (NFC)/Bluetooth functions

You can perform the following operations using the camera's Wi-Fi, NFC One-touch, and Bluetooth functions.

- Saving images to a computer
- Transferring images from the camera to a smartphone
- Using a smartphone as a remote control for the camera
- Viewing still images on a TV
- Recording location information from a smartphone to images
- Transferring images to the FTP server

For details, refer to the "Help Guide" (page 2).

### Installing Imaging Edge Mobile

Imaging Edge Mobile is required to connect the camera and a smartphone. If Imaging Edge Mobile is already installed on your smartphone, be sure to update it to the latest version.

For details on Imaging Edge Mobile, refer to the support page (<https://www.sony.net/iem/>).



#### Note

- To use the camera's NFC One-touch function, an NFC-enabled smartphone or tablet is required.
- The Wi-Fi functions introduced in this manual are not guaranteed to operate on all smartphones or tablets.
- Depending on future version upgrades, the operational procedures or screen displays are subject to change without notice.

## Recording location information to captured images

By using Imaging Edge Mobile, you can obtain location information from a connected smartphone (via Bluetooth communication) and record it to captured images.

For details on the operating procedure, refer to the "Help Guide" (page 2) or the following support page.



<https://www.sony.net/iem/btg/>

## Transferring images to the FTP server

You can use the camera's Wi-Fi function to transfer images to the FTP server.

For details, refer to the "FTP Help Guide."

[https://rd1.sony.net/help/di/ftp/h\\_zz/](https://rd1.sony.net/help/di/ftp/h_zz/)



- Basic knowledge of FTP servers is required.

# Connecting the camera to a wireless access point

Connect the camera to your wireless access point. Before starting the procedure, make sure you have the SSID (name of the access point) and password of your wireless access point with you.

---

**1** MENU →  (Network) → [Wi-Fi Settings] → [Access Point Set.].

---

**2** Use the control wheel to select the access point to which you want to connect. Press the center of the control wheel and enter the password for the wireless access point, then select [OK].

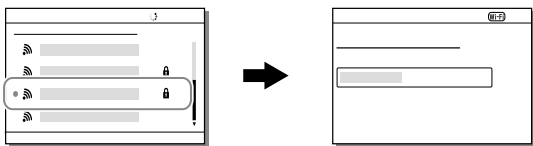

## Note

- If a connection is not established, see the wireless access point operating instructions or contact the administrator of the access point.  
To save images to a computer, install PlayMemories Home on your computer.

PlayMemories Home

<https://www.sony.net/pm/>

## Connecting the camera to a computer

### Connecting to a computer

**1** Insert a sufficiently charged battery pack into the camera.

**2** Turn on the camera and the computer.

**3** Check that [USB Connection] under  (Setup) is set to [Mass Storage].

**4** Connect the camera to the computer using the USB cable.

- When you connect the camera to the computer for the first time, the procedure for recognizing the camera may start automatically on the computer. Wait until the procedure is finished.
- If you connect the camera to your computer using the USB cable when [USB Power Supply] is set to [On], power is supplied from your computer. (Default setting: [On])
- Use the USB Type-C cable (supplied) or a USB-standard cable.
- Use a USB 3.1-compatible computer and the USB Type-C cable (supplied) for higher-speed communications.

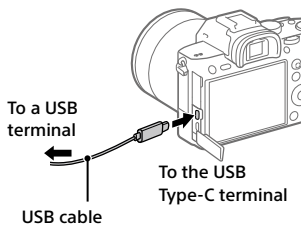

## Disconnecting the camera from the computer

Perform steps 1 and 2 below before performing the following operations:

- Disconnecting the USB cable.
- Removing a memory card.
- Turning off the product.

---

**1** Click  (Safely Remove Hardware and Eject Media) in the taskbar.

---

**2** Click the displayed message.

---

### Note

- On Mac computers, drag and drop the memory card icon or the drive icon into the “Trash” icon. The camera will be disconnected from the computer.
- On Windows 7/Windows 8 computers, the disconnection icon may not appear. In that case, you can skip the steps above.
- Do not remove the USB cable from the camera while the access lamp is lit. The data may be damaged.



# Introduction to computer software

We offer the following computer software to enhance your enjoyment of photos/movies. Access one of the following URLs using your Internet browser and then download the software by following the onscreen instructions.

If one of these software is already installed on your computer, update it to the latest version before use.

For details on the software for computers, refer to the following URL:

<https://www.sony.net/disoft/>

You can check the recommended operating environment for the software from the following URL:

<https://www.sony.net/pcenv/>

## Imaging Edge Desktop

Imaging Edge Desktop is a software suite that includes functions such as remote shooting from a computer, and adjusting or developing RAW images recorded with the camera.

For details on Imaging Edge Desktop, refer to the following URL.

<https://www.sony.net/iex/>

## PlayMemories Home

PlayMemories Home allows you to import still images and movies to your computer and view or use them.

You need to install PlayMemories Home to import XAVC S movies or AVCHD movies to your computer.

You can access the download website directly from the following URL:

<https://www.sony.net/pm/>

- When you connect the camera to your computer, new functions may be added to PlayMemories Home. Connecting the camera to your computer is therefore recommended even if PlayMemories Home has already been installed on the computer.

## Using MENU items

You can change settings related to all the camera operations including shooting, playback, and operating method. You can also execute camera functions from the MENU.

- 1 Press the MENU button to display the menu screen.**

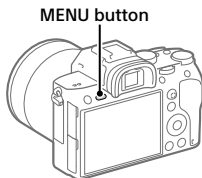

- 2 Select the desired setting you want to adjust using the top/bottom/left/right sides of the control wheel or by turning the control wheel, and then press the center of the control wheel.**

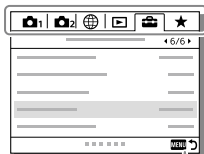

Select an icon at the top of the screen and press the left/right side of the control wheel to move to another MENU item.



Press the MENU button to go back to the previous screen.









- 3 Select the desired setting value, and press the center to confirm your selection.**







# List of MENU items











For details on each MENU items, refer to the reference page in the last column or the Help Guide.

## 1 (Camera Settings 1)

Red tab



Quality/Image Size		
 File Format	Sets the file format for still images. ([RAW] / [JPEG], etc.)	47
 RAW File Type	Selects the file type for RAW images.	Help Guide
 JPEG Quality	Selects the JPEG image quality for [RAW & JPEG] or [JPEG] under [  File Format].	47
 JPEG Image Size	Selects the size of still images. (L / M / S)	46
 Aspect Ratio	Selects the aspect ratio for still images.	Help Guide
APS-C/Super 35mm	Sets whether to record in APS-C-equivalent size for still images and Super 35 mm-equivalent size for movies.	Help Guide
 Long Exposure NR	Sets noise reduction processing for shots with a shutter speed of 1 second or longer.	Help Guide
 High ISO NR	Sets noise reduction processing for high-sensitivity shooting.	Help Guide
 Color Space	Changes the color space (range of reproducible colors).	Help Guide
Lens Comp.	Selects the type of lens compensation.	Help Guide
Shoot Mode/Drive		
Drive Mode	Sets the drive mode, such as for continuous shooting. ([Self-timer] / [Cont. Bracket], etc.)	41, Help Guide

<b>Bracket Settings</b>	Sets self-timer shooting in bracket mode, shooting order for exposure bracketing, and white balance bracketing.	Help Guide
<b>Px. Shift Multi Shoot.</b>	Activates pixel shift multi shooting, which allows you to create higher-resolution images on a computer.	Help Guide
<b>MR  1/ 2 Recall</b>	Calls up settings pre-registered to [ <b>MR  1/ 2 Memory</b> ].	Help Guide
<b>MR  1/ 2 Memory</b>	Registers the desired modes and camera settings.	Help Guide
<b>MR Select Media</b>	Selects the memory card slot from which settings are recalled or to which settings are registered for M1 through M4.	Help Guide
<b>Reg Cust Shoot Set</b>	Assign functions to the custom key to recall when shooting.	Help Guide
 <b>Intvl. Shoot. Func.</b>	Configures settings for interval shooting.	Help Guide
<b>AF</b>		
<b>Focus Mode</b>	Selects the focus mode. ([Single-shot AF] / [Continuous AF], etc.)	34
<b>Priority Set in AF-S</b>	Sets the timing of the shutter release when [Focus Mode] is set to [Single-shot AF], [DMF] or [Automatic AF] with a still subject.	Help Guide
<b>Priority Set in AF-C</b>	Sets the timing of the shutter release when [Focus Mode] is set to [Continuous AF] or [Automatic AF] with a moving subject.	Help Guide
<b>Focus Area</b>	Selects the area of focus. ([Wide] / [Flexible Spot], etc.)	36
<b>Focus Settings</b>	Allows you to focus using the front dial, rear dial or control wheel.	Help Guide

 Swt. V/H AF Area	Sets whether to adjust the [Focus Area] and the position of the focusing frame based on the camera's position (horizontal or vertical).	Help Guide
 AF Illuminator	Sets the AF illuminator, which provides light to aid focusing in dark scenes.	Help Guide
Center Lock-on AF	Sets the function to track a subject and continue focusing when pressing the center of the control wheel in the shooting screen.	Help Guide
Face/Eye AF Set.	Configures settings such as whether the camera focuses with priority on human faces or eyes.	Help Guide
 AF Track Sens	Sets the AF tracking sensitivity for the still image mode.	Help Guide
 AF System	Sets the auto focus method when an LA-EA1/LA-EA3 Mount Adaptor (sold separately) is attached.	Help Guide
 AF w/ shutter	Sets whether to perform auto focusing when the shutter button is pressed halfway down. This is useful when you want to adjust the focus and exposure separately.	Help Guide
 Pre-AF	Sets whether or not to perform auto focus before the shutter button is half pressed.	Help Guide
 Eye-Start AF	Sets whether to use auto focus when you look through the viewfinder if an LA-EA2/LA-EA4 Mount Adaptor (sold separately) is attached.	Help Guide
 AF Area Regist.	Sets whether to move the focusing frame to a preassigned position when shooting still images.	Help Guide
 Del. Reg. AF Area	Deletes the focusing frame position information that was registered using [  AF Area Regist.].	Help Guide

<b>AF Area Auto Clear</b>	Sets whether the focus area is displayed all the time or disappears automatically shortly after focusing.	Help Guide
<b>Disp. cont. AF area</b>	Sets whether or not to display the focus area in [Continuous AF] mode.	Help Guide
<b>Phase Detect. Area</b>	Sets phase detection AF area.	Help Guide
<b>AF Micro Adj.</b>	Finely adjusts the autofocused position, when using the LA-EA2 or LA-EA4 Mount Adaptor (sold separately).	Help Guide
<b>Aperture Drive in AF</b>	Changes the aperture drive system to prioritize the auto-focusing tracking performance or to prioritize silence.	Help Guide
<b>Exposure</b>		
<b>Exposure Comp.</b>	Compensates for the brightness of the entire image.	Help Guide
<b>Reset EV Comp.</b>	Sets whether to maintain the exposure value set using [Exposure Comp.] when you turn off the power when the exposure compensation dial position is set to "0."	Help Guide
<b>ISO</b>	Sets the ISO sensitivity. ([ISO AUTO], etc.)	Help Guide
<b>ISO AUTO Min. SS</b>	Sets the slowest shutter speed at which ISO sensitivity will start to change in [ISO AUTO] mode.	Help Guide
<b>Metering Mode</b>	Selects the method for measuring brightness. ([Multi] / [Spot], etc.)	Help Guide
<b>Face Prty in Mlti Mtr</b>	Sets whether the camera measures brightness based on detected faces when [Metering Mode] is set to [Multi].	Help Guide

<b>Spot Metering Point</b>	Sets whether to coordinate the spot metering point with the focus area when [Focus Area] is set to [Flexible Spot] or [Expand Flexible Spot].	Help Guide
<b>Exposure step</b>	Selects the size of the increment step for shutter speed, aperture, and exposure compensation values.	Help Guide
 <b>AEL w/ shutter</b>	Sets whether to lock the exposure when the shutter button is pressed halfway down. This is useful when you want to adjust the focus and exposure separately.	Help Guide
<b>Exposure Std. Adjust</b>	Adjusts the standard for the correct exposure value for each metering modes.	Help Guide
<b>Flash</b>		
<b>Flash Mode</b>	Sets the flash settings.	Help Guide
<b>Flash Comp.</b>	Adjusts the intensity of flash output.	Help Guide
<b>Exp. comp. set</b>	Sets whether to reflect exposure compensation value to flash compensation.	Help Guide
<b>Wireless Flash</b>	Sets whether to shoot with the wireless flash.	Help Guide
<b>Red Eye Reduction</b>	Reduces the red-eye phenomenon when using flash.	Help Guide
<b>External Flash Set.</b>	Configures the settings of a flash (sold separately) attached to the camera using the monitor and control wheel of the camera.	Help Guide
<b>Color/WB/Img. Processing</b>		
<b>White Balance</b>	Corrects the tone effect of the ambient light to shoot whitish objects in a white tone. ([Auto] / [Daylight], etc.)	Help Guide









<b>Priority Set in AWB</b>	Selects which tone to prioritize when shooting under lighting conditions such as incandescent light with [White Balance] set to [Auto].	Help Guide
<b>DRO/Auto HDR</b>	Analyzes the contrast of light and shadow between the subject and the background by dividing the image into small areas, and creates an image with the optimal brightness and gradation.	Help Guide
<b>Creative Style</b>	Selects the desired image processing. You can also adjust contrast, saturation, and sharpness. ([Vivid] / [Portrait], etc.)	Help Guide
<b>Picture Effect</b>	Shoots images with a texture unique to the selected effect. ([Toy Camera] / [Rich-tone Mono.], etc.)	Help Guide
<b>Picture Profile</b>	Changes settings such as color and tone when recording images. * This function is for skilled movie creators.	Help Guide
<b>Focus Assist</b>		
<b>Focus Magnifier</b>	Enlarges the image before shooting so that you can check the focus.	Help Guide
<b>Focus Magnif. Time</b>	Sets the length of time the image will be shown in an enlarged form.	Help Guide
 <b>Initial Focus Mag.</b>	Sets the initial magnification scale when using [Focus Magnifier].	Help Guide
 <b>AF in Focus Mag.</b>	Sets whether or not to autofocus when an enlarged image is being displayed. While the enlarged image is being displayed, you can focus within a smaller area than the flexible spot.	Help Guide
 <b>MF Assist</b>	Displays an enlarged image when focusing manually.	Help Guide







<b>Peaking Setting</b>	Sets the peaking function, which enhances the outline of in-focus areas when focusing manually.	Help Guide
<b>Shoot Assist</b>		
 <b>Anti-flicker Shoot.</b>	Detects flickering/blinking from artificial light sources such as fluorescent lighting and times the shooting of images to moments when flickering will have less of an impact.	Help Guide
<b>Face Registration</b>	Registers or changes the person to be given priority when focusing.	Help Guide
<b>Regist. Faces Priority</b>	Detects the registered face with higher priority using [Face Registration].	Help Guide



## 2 (Camera Settings 2)

Purple tab





<b>Movie</b>		
 <b>Exposure Mode</b>	Sets the exposure mode when shooting movies.	Help Guide
 <b>S&amp;Q Exposure Mode</b>	Sets the exposure mode when shooting slow-motion/quick-motion movies.	Help Guide
 <b>File Format</b>	Selects the movie file format. ([XAVC S 4K] / [AVCHD], etc.)	48
 <b>Record Setting</b>	Selects a frame-rate and bit-rate for the movie.	49
 <b>S&amp;Q S&amp;Q Settings</b>	Changes the settings for slow-motion and quick-motion movie shooting.	Help Guide
 <b>Proxy Recording</b>	Records low-bit-rate proxy files simultaneously when recording XAVC S movies.	Help Guide
 <b>AF drive speed</b>	Switches focusing speed when using autofocus in movie mode.	Help Guide
 <b>AF Track Sens</b>	Sets the AF tracking sensitivity for the movie mode.	Help Guide



 <b>Auto Slow Shut.</b>	Sets the function that automatically adjusts the shutter speed following the brightness of the environment in movie mode.	Help Guide
<b>Audio Recording</b>	Sets whether to record audio when shooting a movie.	Help Guide
<b>Audio Rec Level</b>	Adjusts the audio recording level during movie recording.	Help Guide
<b>Audio Level Display</b>	Sets whether to display the audio level.	Help Guide
<b>Audio Out Timing</b>	Sets the timing of audio output during the movie recording.	Help Guide
<b>Wind Noise Reduct.</b>	Reduces wind noise during movie recording.	Help Guide
 <b>Marker Display</b>	Sets whether to display markers on the monitor when recording movies.	Help Guide
 <b>Marker Settings</b>	Sets which markers to display on the monitor when recording movies.	Help Guide
<b>Video Light Mode</b>	Sets the illumination setting for the HVL-LBPC LED light (sold separately).	Help Guide
<b>Movie w/ shutter</b>	Records movies using the shutter button.	Help Guide
<b>Shutter/SteadyShot</b>		
 <b>Silent Shooting</b>	Shoots images without the shutter sound.	Help Guide
<b>e-Front Curtain Shut.</b>	Sets whether to use the electronic front curtain shutter function.	Help Guide
<b>Release w/o Lens</b>	Sets whether to release the shutter when the lens is not attached.	Help Guide
<b>Release w/o Card</b>	Sets whether to release the shutter when a memory card is not inserted.	Help Guide
<b>SteadyShot</b>	Sets whether to activate SteadyShot for shooting.	Help Guide
<b>SteadyShot Settings</b>	Sets SteadyShot settings.	Help Guide

Zoom		
<b>Zoom</b>	Sets the zoom scale for zoom functions other than the optical zoom.	Help Guide
<b>Zoom Setting</b>	Sets whether to use the Clear Image Zoom and Digital Zoom when zooming.	Help Guide
<b>Zoom Ring Rotate</b>	Assigns the zoom in/out to the rotational direction of the zoom lens. This function is only available with a power zoom lens that is compatible with this function.	Help Guide
Display/Auto Review		
<b>DISP Button</b>	Sets the type of information to be displayed on the monitor or in the viewfinder when the DISP button is pressed.	Help Guide
<b>FINDER/MONITOR</b>	Sets the method for switching the display between the electronic viewfinder and the monitor.	Help Guide
 <b>Finder Frame Rate</b>	Sets the frame rate for the viewfinder when shooting still images.	Help Guide
<b>Zebra Setting</b>	Sets the stripes displayed to adjust brightness.	Help Guide
<b>Grid Line</b>	Displays grid lines for adjusting the image composition.	Help Guide
<b>Exposure Set. Guide</b>	Sets the guide displayed when exposure settings are changed in the shooting screen.	Help Guide
<b>Live View Display</b>	Sets whether to reflect settings such as exposure compensation in screen display.	Help Guide
<b>Cont. Shoot. Length</b>	Sets whether to display an indicator of the remaining time for which continuous shooting can be performed at the same shooting speed.	42
<b>Auto Review</b>	Sets auto review to display the captured image after shooting.	Help Guide

Custom Operation		
 Custom Key	Assigns functions to the various keys so that you can perform operations more quickly by pressing the keys when shooting still images.	Help Guide
 Custom Key	Assigns functions to the various keys so that you can perform operations more quickly by pressing the keys when shooting movies.	Help Guide
 Custom Key	Assigns functions to the keys so that you can perform operations more quickly by pressing the keys when playing back images.	Help Guide
<b>Function Menu Set.</b>	Customizes the functions displayed when the Fn (Function) button is pressed.	Help Guide
<b>Dial Setup</b>	Sets the functions of the front and rear dials when the exposure mode is set to M. Dials can be used for adjusting shutter speed and aperture value.	Help Guide
<b>Av/Tv Rotate</b>	Sets the direction of turning the front or rear dial or the control wheel to adjust the aperture value or shutter speed.	Help Guide
<b>Dial Ev Comp</b>	Sets whether to compensate the exposure with the front or rear dial.	Help Guide
<b>MOVIE Button</b>	Enables or disables for the MOVIE button.	Help Guide
<b>Lock Operation Parts</b>	Sets whether to disable the multi-selector, control wheel, or front and rear dials temporarily when the Fn button is pressed and held down.	Help Guide
<b>Audio signals</b>	Selects whether the camera beeps during auto focus and self-timer operations.	Help Guide
<b>Function Ring(Lens)</b>	Assigns a function to the function ring on the lens.	Help Guide

<b>Snd to Smrtphn Func</b>	Sets movies to be transferred to a smartphone, or transfers images to a smartphone.	Help Guide
<b>Send to Computer</b>	Backs up images by transferring them to a computer connected to a network.	Help Guide
<b>FTP Transfer Func.</b>	Sets image transfer using FTP and executes it. * Basic knowledge of FTP server is required.	53
<b>View on TV</b>	Allows you to view images on a network-enabled TV.	Help Guide
<b>Ctrl w/ Smartphone</b>	Sets the condition for connecting the camera to a smartphone.	Help Guide
<b>Airplane Mode</b>	Disables wireless communications from the device such as Wi-Fi, NFC, and Bluetooth function.	Help Guide
<b>Wi-Fi Settings</b>	Allows you to register your access point and check or change the Wi-Fi connection information.	Help Guide
<b>Bluetooth Settings</b>	Controls the settings for connecting the camera with a smartphone via a Bluetooth connection.	Help Guide
 <b>Loc. Info. Link Set.</b>	Obtains location information from the paired smartphone and records it to captured images.	Help Guide
<b>Edit Device Name</b>	Changes the device name under Wi-Fi Direct, etc.	Help Guide
<b>Imp Root Certificate</b>	Imports a root certificate to the camera.	Help Guide
<b>Reset Network Set.</b>	Resets all the network settings.	Help Guide
<b>Bluetooth Rmt Ctrl</b>	Sets whether or not to use a Bluetooth remote commander.	Help Guide

<b>Protect</b>	Protects recorded images against accidental erasure.	Help Guide
<b>Rotate</b>	Rotates the image.	Help Guide
<b>Delete</b>	Deletes images.	Help Guide
<b>Rating</b>	Assigns rating to recorded images on a scale from ★ to ★★.	Help Guide
<b>Rating Set (Cust Key)</b>	Sets the rating (number of ★) that can be selected using the custom key to which [Rating] has been assigned with [  Custom Key].	Help Guide
<b>Specify Printing</b>	Specifies in advance on the memory card which still images to print out later.	Help Guide
<b>Copy</b>	Copies images from the memory card in the memory card slot designated in [Select PB Media] to the memory card in the other slot.	Help Guide
<b>Photo Capture</b>	Captures a chosen scene in a movie to save as a still image.	Help Guide
 <b>Enlarge Image</b>	Enlarges the playback images.	Help Guide
 <b>Enlarge Init. Mag.</b>	Sets the initial magnification scale when playing back enlarged images.	Help Guide
 <b>Enlarge Initial Pos.</b>	Sets the initial magnification area when playing back enlarged images.	Help Guide
<b>Slide Show</b>	Plays a slide show.	Help Guide
<b>Select PB Media</b>	Selects the memory card slot of the memory card to be played back.	Help Guide
<b>View Mode</b>	Plays back images from a specified date or specified folder of still images and movies.	Help Guide

<b>Image Index</b>	Displays multiple images at the same time.	Help Guide
<b>Disp Cont Shoot Grp</b>	Sets whether to display continuously shot images as a group.	Help Guide
<b>Display Rotation</b>	Sets the playback orientation for images shot vertically.	Help Guide
<b>Image Jump Setting</b>	Sets which dial and method to use for jumping between images during playback.	Help Guide
<b>Cont. PB for  Interval</b>	Continuously plays back images shot using interval shooting.	Help Guide
<b>PB Speed for  Interval</b>	Sets the playback speed when continuously playing back images with [Cont. PB for  Interval].	Help Guide

## (Setup)

Yellow tab

<b>Monitor Brightness</b>	Adjusts the brightness of the screen.	Help Guide
<b>Viewfinder Bright.</b>	Sets the brightness of the electronic viewfinder.	Help Guide
<b>Finder Color Temp.</b>	Sets the color temperature of the viewfinder.	Help Guide
<b>Gamma Disp. Assist</b>	Adjusts the screen to make monitoring easier when displaying an S-Log or HLG movie.	Help Guide
<b>Volume Settings</b>	Sets the volume for movie playback.	Help Guide
<b>Delete confirm.</b>	Sets whether [Delete] or [Cancel] is preselected in the delete confirmation screen.	Help Guide

<b>Display Quality</b>	Sets the display quality. * When [High] is selected, the battery is consumed more quickly. * When the temperature of the camera is high, [Display Quality] may be locked to [Standard].	Help Guide
<b>Pwr Save Start Time</b>	Sets the time intervals to automatically switch to power save mode.	Help Guide
<b>Auto Pwr OFF Temp.</b>	Sets the camera temperature at which the camera turns off automatically during shooting. When shooting in hand-held mode, set to [Standard].	Help Guide
<b>NTSC/PAL Selector*1</b>	Changes the TV format of the device so that you can shoot in a different movie format.	Help Guide
<b>Cleaning Mode</b>	Starts the cleaning mode to clean the image sensor.	Help Guide
<b>Touch Operation</b>	Sets whether or not to activate the touch operation of the monitor.	43
<b>Touch Panel/Pad</b>	Selects whether to activate touch panel operation when shooting with the monitor, or touch pad operation when shooting with the viewfinder.	43
<b>Touch Pad Settings</b>	Adjusts settings related to touch pad operation.	Help Guide
<b>Demo Mode</b>	Sets demonstration playback of movies to on or off.	Help Guide
<b>TC/UB Settings</b>	Sets the time code (TC) and user bit (UB). * This function is for skilled movie creators.	Help Guide
<b>IR Remote Ctrl</b>	Sets whether to use the infrared remote control.	Help Guide



<b>HDMI Settings</b>	Sets the HDMI settings. * Images will not appear on the monitor of the camera if you record movies while the camera is connected to an HDMI device with [File Format] set to [XAVC S 4K].	Help Guide
<b>4K Output Sel.</b>	Sets how to record and output 4K movies via HDMI when the camera is connected to an external recorder/ player that supports 4K.	Help Guide
<b>USB Connection</b>	Sets the USB connection method.	Help Guide
<b>USB LUN Setting</b>	Enhances compatibility by limiting the functions of USB connection. Set to [Multi] in normal conditions and to [Single] only when the connection cannot be established.	Help Guide
<b>USB Power Supply</b>	Sets whether to supply power via USB connection when the camera is connected to a computer or USB device.	Help Guide
<b>PC Remote Settings</b>	Controls the PC remote shooting settings.	Help Guide
<b>Language</b>	Selects the language.	31
<b>Date/Time Setup</b>	Sets the date, time, and daylight savings.	31
<b>Area Setting</b>	Sets the location of use.	Help Guide
<b>Copyright Info</b>	Sets copyright information for still images.	Help Guide
<b>Format</b>	Formats the memory card.	Help Guide
<b>File Number</b>	Sets the method used to assign file numbers.	Help Guide
<b>Set File Name</b>	Changes the first 3 characters of the file names for still images.	Help Guide
<b>Rec. Media Settings</b>	Sets the method for recording images to two memory card slots.	Help Guide

<b>Select REC Folder</b>	Changes the folder selected for storing still images.	Help Guide
<b>New Folder</b>	Creates a new folder for storing still images.	Help Guide
<b>Folder Name</b>	Sets the folder format for still images.	Help Guide
<b>Recover Image DB</b>	Recovers the image database file and enables recording and playback.	Help Guide
<b>Display Media Info.</b>	Displays the remaining recording time of movies and the recordable number of still images on the memory card.	Help Guide
<b>Version</b>	Displays the camera software version.	Help Guide
<b>Setting Reset</b>	Restores settings to their defaults. Select [Initialize] to restore all settings to their default values.	Help Guide

## ★ (My Menu)

Gray tab

<b>Add Item</b>	Adds desired MENU items to ★ (My Menu).	Help Guide
<b>Sort Item</b>	Sorts the MENU items added to ★ (My Menu).	Help Guide
<b>Delete Item</b>	Deletes MENU items added to ★ (My Menu).	Help Guide
<b>Delete Page</b>	Deletes all the MENU items on a page in ★ (My Menu).	Help Guide
<b>Delete All</b>	Deletes all the MENU items added to ★ (My Menu).	Help Guide

\*1 If you change this item, you will need to format the memory card for compatibility with the PAL or NTSC system. Also, note that it may not be possible to play back movies recorded for the NTSC system on PAL system TVs.

# List of icons on the monitor

The displayed contents and their positions in the illustrations are just guidelines, and may differ from the actual displays.

## Icons on the shooting screen

### Monitor mode

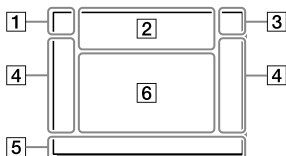

### Viewfinder mode

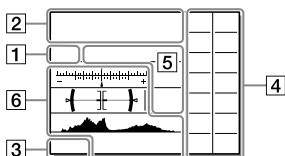

#### 1 Shooting mode/ Scene recognition

i **P P\* A S M**  
**i** [Histogram] [P] [A] [S] [M]  
**S&Q** P S&Q A S&Q S S&Q M

Shooting mode (32)

1 2 3 [M1] [M2] [M3] [M4]

Register number (60)



Scene Recognition icons

#### 2 Camera settings

1 2 [1] [2] [1RAW] [2RAW]  
 [2RAW] [1RAW] [2RAW] [1JPEG] [2JPEG]  
 [1JPEG] [2JPEG] [1R+J] [2R+J] [1R+J]

[2R+J] **NO CARD**

Memory card status (26, 82)

**100**

Remaining number of recordable images

|||||3

Writing data / Number of images left to write

**3:2 16:9**

Aspect ratio of still images (59)

---

**42M 36M 18M 15M 11M 8.9M  
4.5M 3.8M**

Image size of still images (46)

---

**RAW RAW**

RAW recording (compressed/  
uncompressed) (47)

---

**X.FINE FINE STD**

JPEG Quality (47)

---

**XAVC S 4K XAVC S HD AVCHD**

File format of movies (48)

---

**100 60 50 25 16  
FX FH**

Record setting of movies (49)

---

**120p 60p 60i 30p 24p  
100p 50p 50i 25p**

Frame rate of movies (49)

---

**100<sup>2</sup>Px 60<sup>2</sup>Px 50<sup>2</sup>Px 25<sup>2</sup>Px  
16<sup>2</sup>Px**

Proxy Recording (65)

---

**120fps 60fps 30fps 15fps 8fps  
4fps  
100fps 50fps 25fps 12fps 6fps  
3fps 2fps 1fps**

Frame rate for slow/quick  
motion shooting (65)

---



APS-C/Super 35mm (59)

---



Flash charge in progress

---

---

**VIEW**

Setting Effect OFF (67)

---



AF Illuminator (61)

---

**Flicker**

Flickering detected (65)

---



SteadyShot off/on, Camera  
shake warning (66)

---

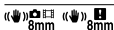

SteadyS. Focal Len./ Camera  
shake warning (66)

---



Smart Zoom /  
Clear Image Zoom / Digital  
Zoom (67)

---

**-PC-**

PC remote (73)

---



Bright Monitoring

---



Silent Shooting (66)

---



Infrared remote control

---



No audio recording of movies  
(66)

---



Wind Noise Reduct. (66)

---



Copyright information writing on (73)

Assist S-Log2 Assist S-Log3 Assist HLG 709 Assist HLG 2020

Gamma Disp. Assist (71)



Focus Cancel (44)



Lock-on AF Cancel

## Spot Focus

Performing [Spot Focus] (45)



NFC active (52)



Bluetooth connection available / Bluetooth connection unavailable (69)



Connected to smartphone / Not connected to smartphone



Obtaining location information/ Location information cannot be obtained (69)



Airplane Mode (69)



Overheating warning



Database file full/Database file error

## 3 Battery



Remaining battery (24)



Remaining battery warning



USB power supply (73)

## 4 Shooting settings

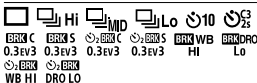

Drive Mode (41)



Flash Mode (63) /  
Wireless Flash (63) /  
Red Eye Reduction (63)



Flash Comp. (63)



Focus Mode (34)

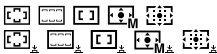

Focus Area (36)



Metering Mode (62)



## 7500K A5 G5

White Balance (Auto, Preset, Underwater Auto, Custom, Color temperature, Color filter) (63)



D-Range Opt./Auto HDR (64)



+3 +3 +3

Creative Style (64)/Contrast, saturation, and sharpness



Picture Effect (64)



Face Priority in AF (61)



Picture Profile (64)



Prioritize Rec. Media (73)

## 5 Focus indicator/exposure settings



Focus indicator (35)

1/250

Shutter speed

F3.5

Aperture value



Exposure compensation (62)/Metered Manual

ISO400 ISO AUTO

ISO sensitivity (62)



AE lock/ FEL lock

## 6 Guides/other

● Lock-on AF

● Lock-on AF Cancel

Guide display for Lock-on AF (61)

● Focus Cancel

Guide display for canceling focusing (44)



Bracket indicator



Spot metering area (62)

---

320 400 500  
5.0 5.6 6.3

Exposure Setting Guide (67)

---

1 1/125 1/250 1/500 1/1000 1/2000 1/4000 1/8000 1/16000

Shutter speed indicator

---

1/16 1/8 1/4 1/2 1 2 4 8 16 32 64 128 256 512 1024

Aperture indicator

---



Histogram

---



Digital level gauge

---

**STBY REC**

Movie recording standby/Movie recording in progress

---

**1:00:12**

Actual movie recording time  
(hours: minutes: seconds)

---



Audio Level Display (66)

---

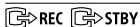

REC Control (73)

---

**00:00:00:00**

Time code (hours: minutes:  
seconds: frames) (72)

---

**00 00 00 00**

User Bit (72)

---



1" 15" 30"  
Px. Shift Multi Shoot.

---

## Icons on the playback screen

### Single-image playback display

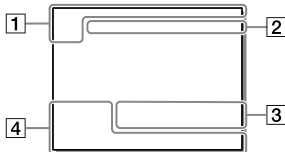

### Histogram display

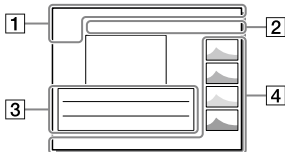

#### 1 Basic information



Playback media (70)



View Mode (70)



Rating (70)



Protect (70)

#### DPOF

DPOF set (70)

#### 3/7

File number/Number of images  
in the view mode



NFC active (52)



Remaining battery (24)



Continuous shooting group  
(71)



Proxy movie included (65)



Px. Shift Multi Shoot.

#### 2 Camera settings

Refer to "Icons on the shooting  
screen" (page 75).

#### 3 Shooting settings



Picture Effect error



Auto HDR error (64)



---

## 35mm

Lens focal length

---

## HLG

HDR recording (Hybrid Log-Gamma)

---

Refer to “Icons on the shooting screen” (page 75) for other icons displayed in this area.

## 4 Image information

---



Latitude/longitude information  
(69)

---

## 2017 - 1 - 1 10:37AM

Date of recording (31)

---

## 100-0003

Folder number – File number  
(73)

---



Histogram (Luminance/R/G/B)

---

## Specifications

### Memory cards that can be used

When using microSD memory cards or Memory Stick Micro media with this camera, be sure to use the appropriate adaptor.

#### SD memory cards

Recording format		Supported memory card
Still image		SD/SDHC/SDXC card
AVCHD		SD/SDHC/SDXC card (Class 4 or faster, or U1 or faster)
XAVC S	4K 60 Mbps* HD 50 Mbps or lower* HD 60 Mbps	SDHC/SDXC card (Class 10, or U1 or faster)
	4K 100 Mbps* HD 100 Mbps	SDHC/SDXC card (U3)



\* Including when recording proxy movies at the same time

#### Memory Stick media

Recording format		Supported memory card
Still image		Memory Stick PRO Duo/ Memory Stick PRO-HG Duo
AVCHD		Memory Stick PRO Duo (Mark 2)/ Memory Stick PRO-HG Duo
XAVC S	4K 60 Mbps* HD 50 Mbps or lower* HD 60 Mbps	Memory Stick PRO-HG Duo
	4K 100 Mbps* HD 100 Mbps	—

\* Including when recording proxy movies at the same time

**Note**

- Use the slot 1 when you are using a UHS-II memory card. Also, select MENU →  (Setup) → [Rec. Media Settings] → [Prioritize Rec. Media] → [Slot 1].
- Memory Stick PRO Duo media cannot be used in the slot 1.
- When an SDHC memory card is used to record an XAVC S movie over extended periods of time, the recorded movies will be divided into files 4 GB in size. The divided files can be handled as a single file by importing them to a computer using PlayMemories Home.
- When recording a movie on memory cards in both the slot 1 and the slot 2 with following camera settings, insert two memory cards with the same file system. XAVC S movies cannot be recorded simultaneously when using a combination of the exFAT file system and FAT32 file system.
  - [File Format] is set to [XAVC S 4K] or [XAVC S HD]
  - [Recording Mode] under [Rec. Media Settings] is set to [Simult.  

Memory card	File system
SDXC memory card	exFAT
Memory Stick PRO Duo (Mark2) Memory Stick PRO-HG Duo SDHC memory card	FAT32

- Charge the battery pack sufficiently before attempting to recover the database files on the memory card.

## Specifications

### Camera

#### [System]

Camera Type:

Interchangeable Lens Digital Camera

Lens: Sony E-mount lens

#### [Image sensor]

Image format: 35 mm full frame  
(35.9 mm × 24.0 mm), CMOS image sensor

Effective pixel number of camera:

Approx. 42 400 000 pixels

Total pixel number of camera:

Approx. 43 600 000 pixels

#### [SteadyShot]

In-camera sensor shift image stabilization system

#### [Auto focus system]

Detection system: Phase detection system/Contrast detection system

Sensitivity Range: -3 EV to +20 EV (at ISO 100 equivalent, F2.0)

#### [Electronic viewfinder]

Total number of dots: 3 686 400 dots

Magnification: Approx. 0.78× with 50 mm lens at infinity,  $-1 \text{ m}^{-1}$

Eye Point: Approx. 23 mm from the eyepiece and approx. 18.5 mm from the eyepiece frame at  $-1 \text{ m}^{-1}$

Diopter Adjustment:

$-4.0 \text{ m}^{-1}$  to  $+3.0 \text{ m}^{-1}$

#### [Monitor]

7.5 cm (3.0 type) TFT drive, touch panel

Total number of dots: 2 359 296 dots

#### [Exposure control]

Metering method: 1 200-zone evaluative metering

Metering Range: -3 EV to +20 EV (at ISO 100 equivalent with F2.0 lens)

ISO sensitivity (Recommended exposure index):

Still images: ISO 100 to ISO 32 000  
(Extended ISO: Minimum ISO 50, maximum ISO 102 400)

Movies: ISO 100 to ISO 32 000 equivalent

#### [Shutter]

Type: Electronically-controlled, vertical-traverse, focal-plane type

Speed range:

Still images: 1/8 000 second to 30 seconds, BULB

Movies: 1/8 000 second to 1/4 second

1080 60i-compatible devices (1080 50i-compatible devices): up to 1/60 (1/50) second in AUTO mode (up to 1/30 (1/25) second in Auto slow shutter mode)

Flash sync speed: 1/250 second (when using a flash manufactured by Sony)

**[Recording format]**

File format: JPEG (DCF Ver. 2.0, Exif Ver. 2.31, MPF Baseline) compliant, RAW (Sony ARW 2.3 format)

Movie (XAVC S format):

MPEG-4 AVC/H.264 XAVC S ver.1.0 format compliant

Video: MPEG-4 AVC/H.264

Audio: LPCM 2ch (48 kHz 16 bit)

Movie (AVCHD format):

AVCHD format Ver. 2.0 compatible

Video: MPEG-4 AVC/H.264

Audio: Dolby Digital 2ch, equipped with Dolby Digital Stereo Creator

- Manufactured under license from Dolby Laboratories.

**[Recording media]**

SLOT 1: Slot for SD cards (UHS-I and UHS-II compatible)

SLOT 2: Multi-slot for Memory Stick PRO Duo media and SD cards (UHS-I compatible)

**[Input/output terminals]**

USB Type-C terminal:

SuperSpeed USB 5Gbps (USB 3.2)

Multi/Micro USB Terminal\*:

Hi-Speed USB (USB 2.0)

- \* Supports Micro USB compatible devices.

HDMI: HDMI type D micro jack

 (Microphone) terminal:

∅ 3.5 mm Stereo mini jack

 (Headphones) terminal:

∅ 3.5 mm Stereo mini jack

 (Flash sync) terminal

**[General]**

Rated input: 7.2 V  3.7 W

Operating temperature:

0 to 40°C (32 to 104°F)

Storage temperature:

-20 to 55°C (-4 to 131°F)

Dimensions (W/H/D) (Approx.):

126.9 × 95.6 × 73.7 mm

126.9 × 95.6 × 62.7 mm

(from grip to monitor)

5 × 3 7/8 × 3 in.

5 × 3 7/8 × 2 1/2 in.

(from grip to monitor)

Mass (Approx.):

657 g (1 lb 7.2 oz) (including battery pack, SD card)

**[Wireless LAN]**

Supported format: IEEE 802.11 b/g/n

Frequency band: 2.4 GHz

Security: WEP/WPA-PSK/WPA2-PSK

Connection method:

Wi-Fi Protected Setup™ (WPS)/

Manual

Access method: Infrastructure mode

**[NFC]**

Tag type: NFC Forum Type 3 Tag compliant

**[Bluetooth communications]**

Bluetooth standard Ver. 4.1

Frequency band: 2.4 GHz

## Battery charger BC-QZ1

Rated input:

100 - 240 V , 50/60 Hz, 0.38 A

Rated output: 8.4 V , 1.6 A

## Rechargeable battery pack NP-FZ100

Rated voltage: 7.2 V 

Design and specifications are subject to change without notice.

### On image data compatibility

- This camera conforms with DCF (Design rule for Camera File system) universal standard established by JEITA (Japan Electronics and Information Technology Industries Association).
- Playback of images recorded with your camera on other equipment and playback of images recorded or edited with other equipment on your camera are not guaranteed.

## Trademarks

- Memory Stick and  are trademarks or registered trademarks of Sony Corporation.
- XAVC S and  are registered trademarks of Sony Corporation.
- "AVCHD" and the "AVCHD" logotype are trademarks of Panasonic Corporation and Sony Corporation.
- Mac is a trademark of Apple Inc., registered in the United States and other countries.
- IOS is a registered trademark or trademark of Cisco Systems, Inc.
- iPhone and iPad are trademarks of Apple Inc., registered in the U.S. and other countries.
- Blu-ray Disc™ and Blu-ray™ are trademarks of the Blu-ray Disc Association.
- DLNA and DLNA CERTIFIED are trademarks of Digital Living Network Alliance.
- USB Type-C® and USB-C® are registered trademarks of USB Implementers Forum.
- USB-IF SuperSpeed USB Trident logo is a registered trademark of USB Implementers Forum, Inc. 
- Dolby, Dolby Audio and double-D symbol are trademarks of Dolby Laboratories.
- The terms HDMI and HDMI High-Definition Multimedia Interface, and the HDMI Logo are trademarks or registered trademarks of HDMI Licensing Administrator, Inc. in the United States and other countries.

- Microsoft and Windows are registered trademarks or trademarks of Microsoft Corporation in the United States and/or other countries.
- SDXC logo is a trademark of SD-3C, LLC.
- Android and Google Play are trademarks or registered trademarks of Google Inc.
- Wi-Fi, the Wi-Fi logo and Wi-Fi Protected Setup are registered trademarks or trademarks of the Wi-Fi Alliance.
- The N Mark is a trademark or registered trademark of NFC Forum, Inc. in the United States and in other countries.
- The Bluetooth® word mark and logos are registered trademarks owned by the Bluetooth SIG, Inc. and any use of such marks by Sony Corporation is under license.
- QR code is a trademark of Denso Wave Inc.
- In addition, system and product names used in this manual are, in general, trademarks or registered trademarks of their respective developers or manufacturers. However, the ™ or ® marks may not be used in all cases in this manual.

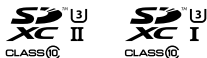

Additional information on this product and answers to frequently asked questions can be found at our Customer Support Website.

<https://www.sony.net/>

## A

AF .....	36
AF-A.....	34
AF-C.....	34
AF-S.....	34
Auto focus.....	36
Auto Mode .....	32
AVCHD.....	48
AWB.....	63

## B

Battery pack.....	25
-------------------	----

## C

Charging.....	24
Clear Image Zoom .....	67
Clock setting .....	31
Computer .....	55, 57
Control wheel.....	19
Custom white balance.....	63

## D

Date/Time Setup .....	31
Delete.....	33
Digital zoom.....	67
Diopter-adjustment .....	13
Direct manual focus.....	34, 40
DISP .....	67
DMF .....	34, 40
DRO .....	64

## F

Fn .....	13, 20
Focus .....	34
Focus indicator.....	35
Function button .....	13

## H

HDR .....	64
Help Guide .....	2

## I

Imaging Edge Desktop .....	57
Imaging Edge Mobile .....	52
In-Camera Guide.....	2
Intelligent Auto .....	32

## L

Language .....	73
Lens.....	28
List of icons .....	75

## M

Memory card.....	26, 82
MENU.....	58
MENU button .....	12, 58
MENU items.....	59
MF.....	34, 39
Monitor.....	75
Movie.....	33, 48
Movie file format.....	48
MOVIE (Movie) button .....	13
Multi-selector.....	20



## **N**

NFC.....	5, 52
Noise reduction.....	59

## **O**

One-touch (NFC).....	52
----------------------	----

## **P**

Playback.....	33
PlayMemories Home .....	57
Printing.....	70
Prioritize Rec. Media .....	27

## **Q**

Quick Navi .....	21
------------------	----

## **R**

RAW.....	47
----------	----

## **S**

Sensitivity.....	62
Smart zoom.....	67
Software.....	57
Specifications.....	84
Still image .....	32

## **T**

Touch Focus .....	44
Touch function.....	43
Touch Operation .....	43
Touch Panel/Pad.....	43

## **V**

Volume.....	71
-------------	----

## **W**

WB.....	63
Wi-Fi .....	5, 52

## **X**

XAVC S 4K.....	48
XAVC S HD .....	48















<https://www.sony.net/SonyInfo/Support/>



5026886110